



Non destructive testing and maintenance service



Ecoglobal S.r.l. Unipersonale

Via M.L. King, 15

29017- Fiorenzuola D'Arda (Piacenza)

Tel. 0523-247134

Fax 0523-248533

mail ecoglobal@ecoglobal.it

Sito web: www.ecoglobal.it



COMPANY

Ecoglobal S.r.l was established in 2003 as freight car maintenance company but, after just a few months, following the arrival of expert and qualified personnel, it specialised in non destructive testing and developed its business to become a service company in this sector.

In just a few years Ecoglobal has become the company of reference in Italy for innovative non destructive testing! The testing methods developed for the Oil & Gas sector have been successfully applied to the railway, nautical and civil sectors.



CERTIFICATIONS



Ecoglobal S.r.l has been awarded UNI EN ISO 9001:2008 certification for the following activities:

1. Feasibility study and design of non destructive tests;
2. Execution of non destructive tests;
3. Training of technicians on non destructive testing;
4. Inspection, maintenance and repair of freight cars, lifting means and plants in general.



CERTIFICATIONS

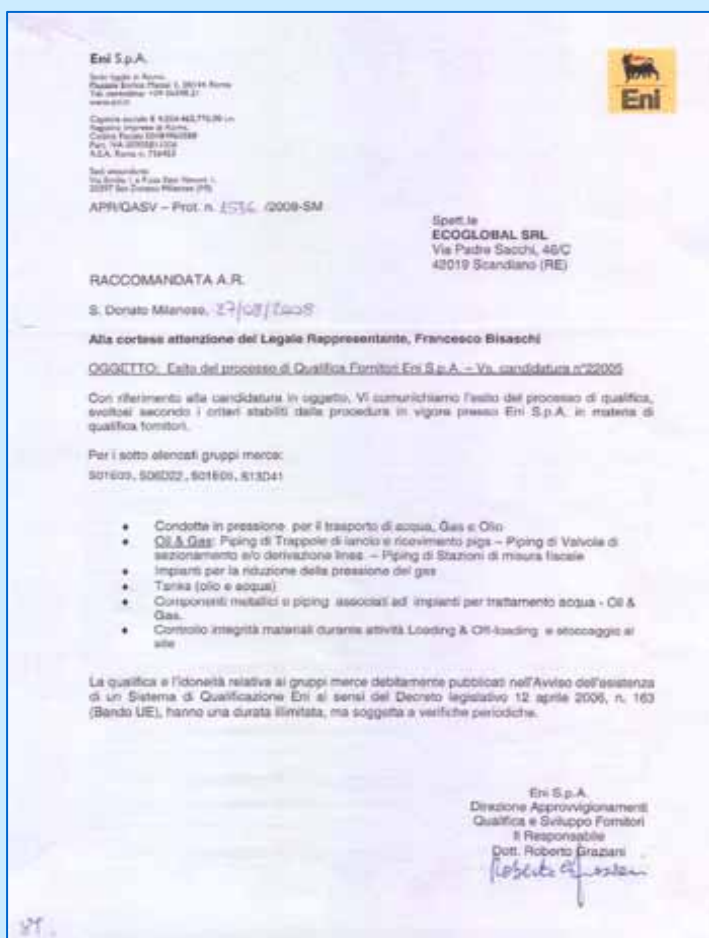

On 27 August, 2008 Ecoglobal has been qualified as supplier by ENI S.p.A..



CERTIFICATIONS



On September 29th, 2011 Ecoglobal has been qualified as company in charge for current maintenance on Trenitalia freight cars.



PERSONNEL QUALIFICATIONS

Ecoglobal technicians have been tested and certified by:

1. the CICPnd (Italian Board for non destructive testing) for level 1, 2 and 3 certification according to the UNI EN 473 standard;
2. the “American Society for Non destructive Testing” (ASNT) for level 3 certification according to the American SNT TC 1° standard;
3. the Istituto Italiano della Saldatura (Italian welding institute) for certification as “International Welding Inspector”.





PERSONNEL QUALIFICATIONS

Ecoglobal S.r.l. employs personnel with level 2 and 3 certifications for the following methods:

- level 2 -3 non destructive testing – Dye Penetrant testing method (PT);
- level 2 -3 non destructive testing – Magnetic particle testing method (MT);
- level 2 -3 non destructive testing – Ultrasonic testing method (UT);
- level 2 -3 non destructive testing – Radiographic testing method (RT)
- level 2 -3 non destructive testing – Visual testing method (VT);
- level 2 non destructive testing – Phased Array method (PA);
- level 2 non destructive testing – Time of flight diffraction method (TOFD);
- International Welding Inspector.



SECTORS OF OPERATION

Ecoglobal operates in the following sectors:

- Oil & Gas structures (Oil pipelines/Methane pipelines/Compressor plants, etc);
- piling and platforms;
- tanks;
- petrochemical plants/refineries, etc;
- drilling;
- bridges;
- lighting poles;
- railway axles;
- hulls.





OIL & GAS

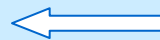

Innovative testing methods applied to the Oil & Gas sector:

Guided waves (screening of underground piping, risers, plants and refineries);

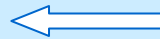

Automatic UT phased array (testing of welding instead of radiography method);

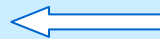
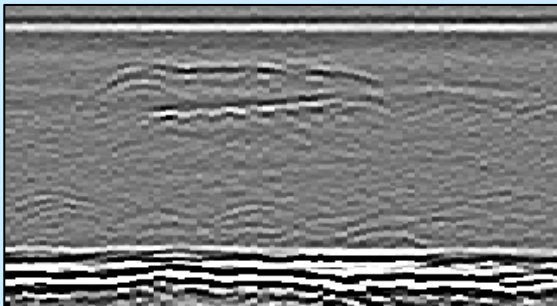

Ultrasonic Time Of Flight Diffraction TOFD (testing of welding and pipes).



BUILDINGS



Traditional testing methods:

Dye penetrant

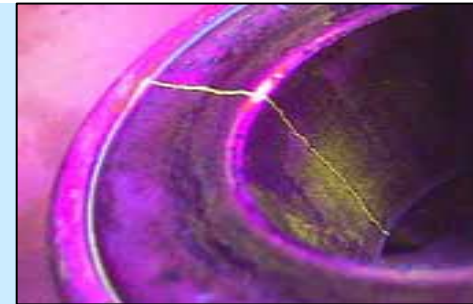

Visual testing



Magnetic particle testing





PLANTS

Traditional testing methods:



acoustic emissions;

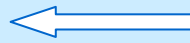

manual and semi-automatic ultrasonic testing;

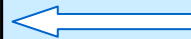
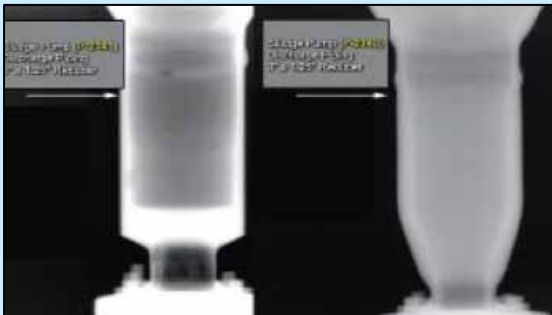

digital radiography.



PERIODIC TESTING OF CRANES AND OVERHEAD CRANES



Ecoglobal carries out maintenance and periodic checks of overhead cranes, cranes, lifting baskets and other lifting systems.



Ecoglobal provides structural inspections and inspections of lifting ropes.



PIPELINES

Latest innovative application using the Guided Waves method

For monitoring corrosion of underground pipelines Ecoglobal installs bands of guided wave transducers. In this way the periodic collection of data will show any change in the integrity of the pipeline.

Underground installation



Sea installation





PIPELINES

Latest collaboration with SIG using the Guided Waves method

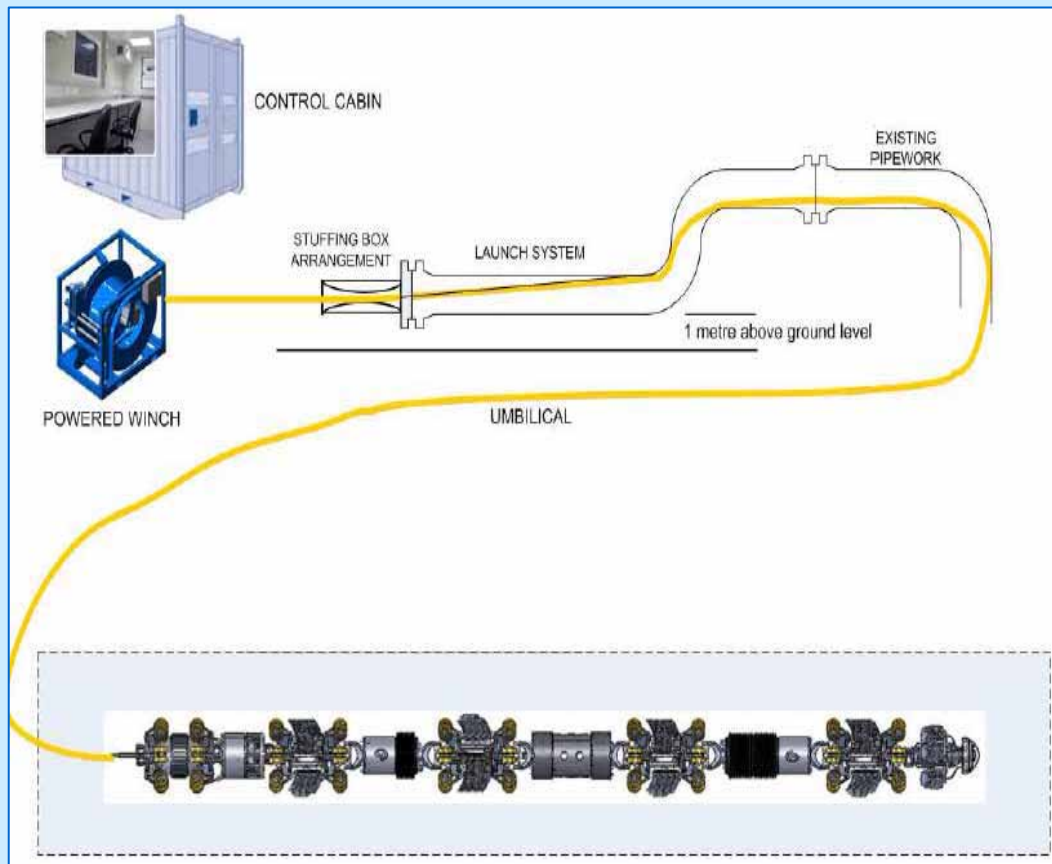

Ecoglobal is partner of SIG in the development and set up of the Guided Waves Pig (IMV).

With this unique kind of pig (IMV) it will be possible to test pipelines without stopping the flow or reducing working pressure.



CIVIL SECTOR



In the civil engineering sector Ecoglobal carries out the following types of tests:

← georadar studies;



← ultrasonic testing;



CIVIL SECTOR

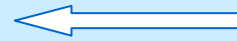

failure analyses;
seismic tests;
cross-hole;
thermography;
endoscopy;
vibration measurement;
coring;
penetrometry;
sclerometry.

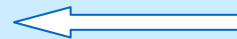



DRILLING SECTOR



Ecoglobal carries out maintenance and NDT of the following materials used in the water and oil drilling sector:

- Masts, substructures, crown/travelling blocks;
- drill pipe tongs, elevators, slips, etc;
- gate valves, spools, etc;
- drill pipes.



DRILLING SECTOR



Ecoglobal has personnel qualified to support the activities of drilling rig off shore NDT certification.





DRILLING SECTOR

Ecoglobal has personnel qualified to support the activities of drilling rig on shore NDT certification.





RAILWAY SECTOR



In the railway sector Ecoglobal carries out the following activities:

- Testing, maintenance and repair of mechanical components of freight cars such as wheel arrangement, brakes, buffers and traction systems;
- Phased Array inspection of axles;
- Guided Waves tests of tracks.



RAILWAY SECTOR

Our repair and maintenance service on rolling stock for Cargo transport is performed onsite in client's railway cargo terminal using mobile equipped means and specialized technicians, trained in Trenitalia workshops.

Ours services on site are carried out by 24 hours from call.





INSPECTION OF AXLES ON ROLLING STOCK

Ecoglobal prides itself on furnishing state-of-the-art services and reliable research, and has developed a new ultrasonic PHASED ARRAY method of inspecting the axles on rolling stock.

This type of control enables us to identify small reflectors in critical areas that could be an early sign of fatigue in the material.

The irregularities detected can be monitored by increasing the frequency of the inspections normally scheduled, in order to ensure the best possible evaluation of any changes.



INSPECTION OF AXLES ON ROLLING STOCK

In addition to inspection with ultrasonic control, the system also provides for automatic registration on a file of the data readings, so as to guarantee the traceability and comparability in time of the inspection made.

To develop this system we studied, obtaining exceptional results in terms of signal resolution:

- calibration samples for axles on rolling stock for light trains (subway cars)
- calibration samples for axles on rolling stock used for freight
- freight car axles in use.



INSPECTION OF AXLES ON ROLLING STOCK

Basically, the phased array method we use differs from the ultrasonic method used by the state railroad company as regards its ability:

- to identify even minor irregularities

- to provide automatic registration on files of the inspection made, so as to guarantee traceability

As it is a highly practical method, the inspections can be made directly at the stations and in the terminals or plants.

Timing and costs necessary for inspections are greatly reduced.



INSPECTION OF AXLES ON ROLLING STOCK



← axes



Contact surface for inspection

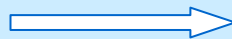



INSPECTION OF AXLES ON ROLLING STOCK

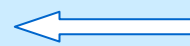

manual scanning

Phased array instrument screen

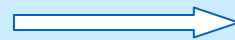



EXAMPLES OF FAULT DETECTION ON COMPLEX CONFIGURATIONS



Faulty axle

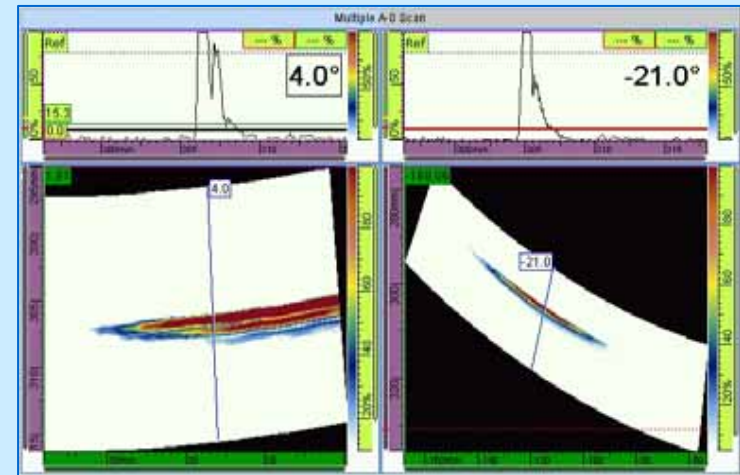
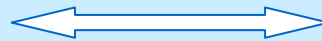

Damaged thread

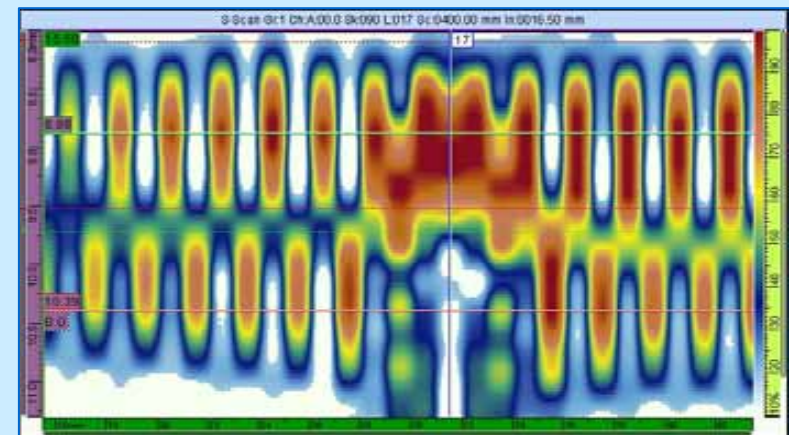
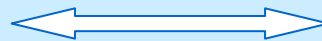



NAUTICAL



Ecoglobal has developed an innovative inspection and survey procedure for the nautical sector, in collaboration with the MPSV Consortium in Piacenza (research and technological transfer laboratory of the Emilia Romagna High Technology network).

The objective of the survey is to identify small delamination defects in composite materials and fibreglass.

With this procedure Ecoglobal can detect small defects in composite materials and fibreglass whereas “competitors” can normally only detect larger faults.



EXAMPLES OF DETECTION OF SMALL DEFECTS IN FIBREGLASS

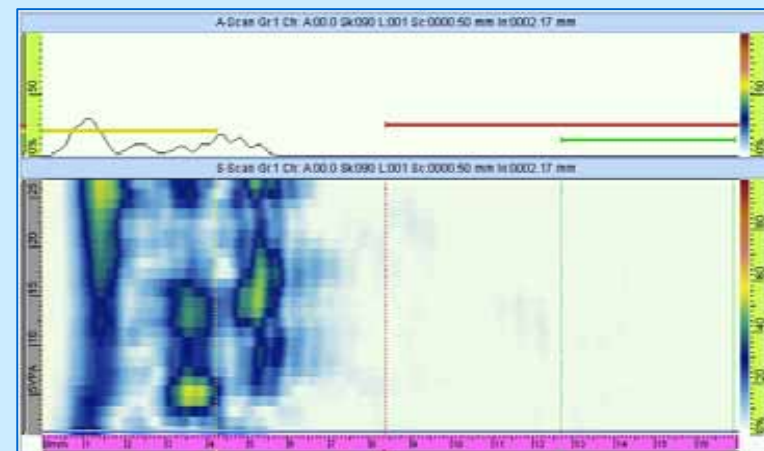
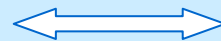
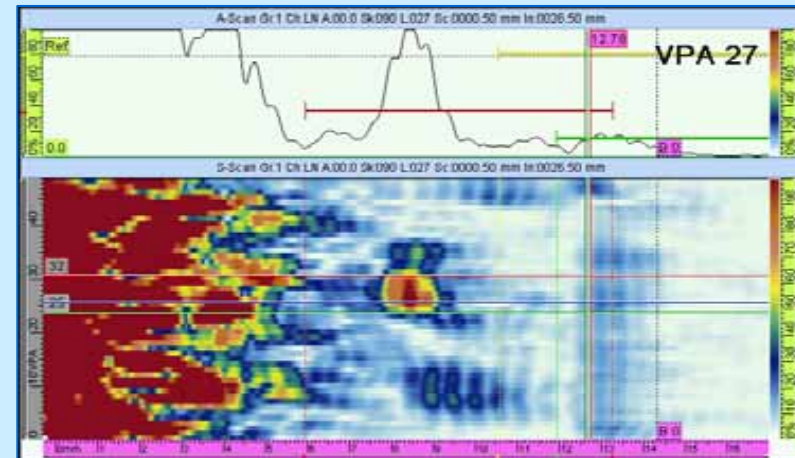
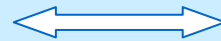
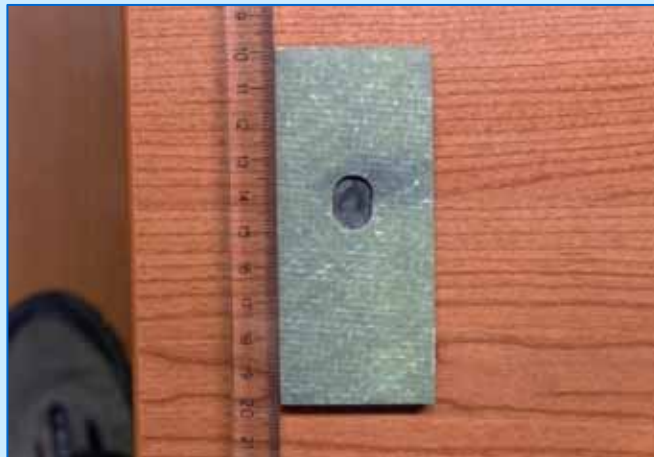



TRAINING



Ecoglobal organises and carries out training, specialization and certification courses for technical staff:

- we have a suitable structure and highly skilled teachers qualified to train technicians;
- courses include theory and practical training;
- the most advanced technological equipment is available in the laboratory including sample pipes with faults to reproduce a true working situation.



TRAINING



At the end of the courses participants are getting an attendance certificate with which they can then choose which certification to obtain:

- 1) Certification with final exam carried out by the external company Sige for ASNT certification;
- 2) Certification with final exam carried out by CIC PND for the issue of EN 473 certificates.



NON DESTRUCTIVE TESTING

Thanks to continuous investment in state-of-the-art means and equipment and to constant personnel training, Ecoglobal has a company structure capable of providing different methods of non destructive testing.

Ecoglobal is the company of reference in Italy for the following innovative non destructive testing methods:

- guided waves;
- ultrasonic Phased array;
- tofd;
- corrosion mapping.



GUIDED WAVES

Inspection using guided waves detects the slightest variations in acoustic impedance and echo characteristics (symmetry/asymmetry).

This screening method developed to detect corrosion can be used (with minimum preparation of the external surface) to rapidly detect and assess faults on the inside and outside of surface and underground piping, with or without coating, even when in operation.



GUIDED WAVES

Different types of piping can be easily tested:

- underground;
- insulated;
- raised;
- lined and in concrete walls.

Detectable defects:

- internal and external corrosion;
- corrosion under the coating.





ADVANTAGES

- Low relative cost for one scan which can cover up to 100% of the inspection;
- Typical range of 60 meters from one position in two directions;
- Working capacity tested up to a temperature of 125 °C.
- Capacity to detect corroded areas with a 3% section variation,
- Recording on file of scan carried out.



INSTRUMENTS FOR GUIDED WAVES TESTING

G3 EQUIPMENT





GUIDED WAVES INSPECTION GRAPH

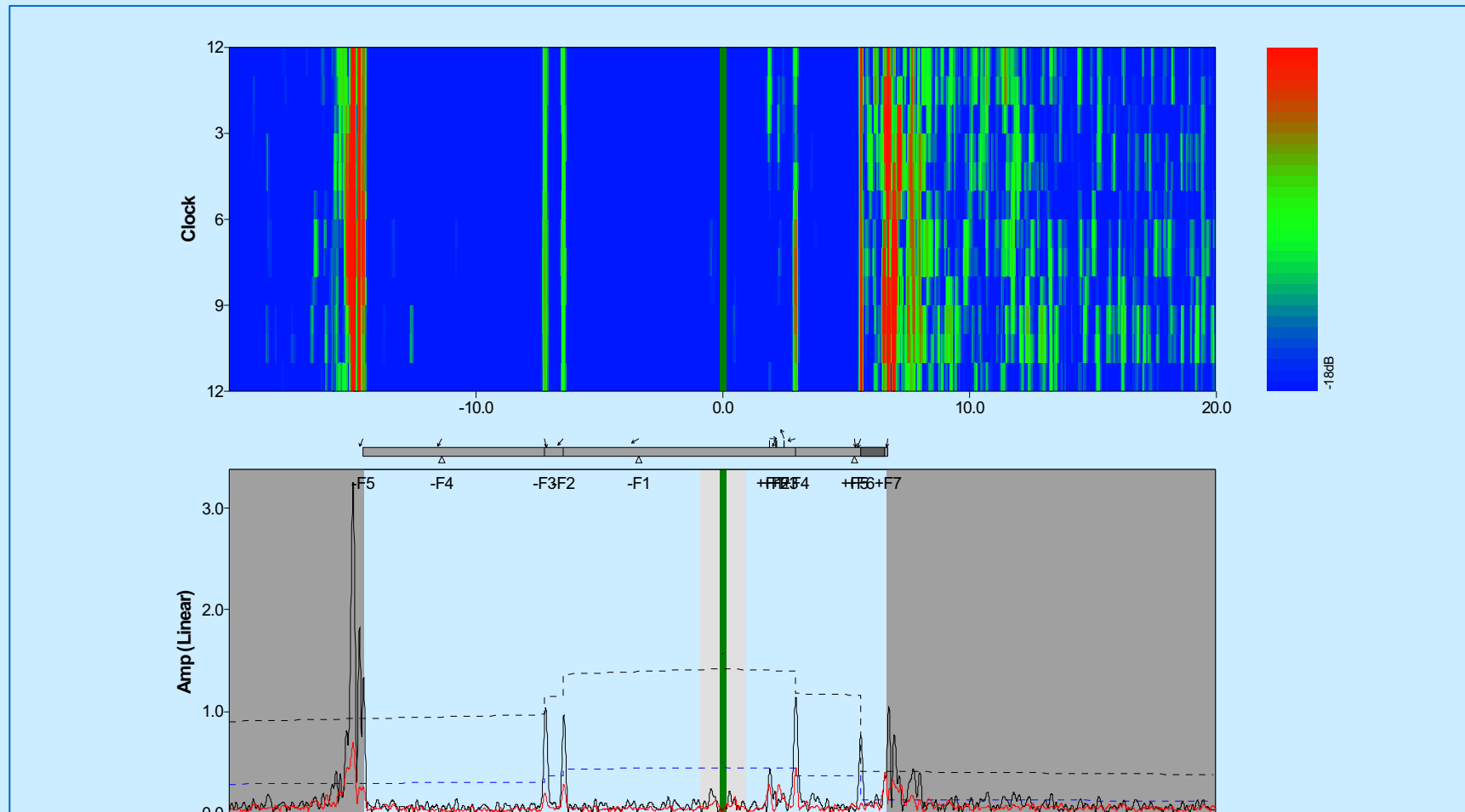

EXAMPLE OF INSPECTED PIPELINES



UNDERGROUND



AERIAL





EXAMPLE OF LAMP POST TESTING



Following the falling of several street lamp post which have caused fatal accidents Ecoglobal has developed a non invasive testing method which is very effective and economic.

This method tests the integrity of the pole in terms of corrosion thus establishing the residual life of the pole.

Ecoglobal first presented this method in Italy at the civil protection exhibition in Bolzano and since then it has been successfully adopted in various Italian municipalities.



AUTOMATIC AND SEMI-AUTOMATIC ULTRASONIC PHASED ARRAY

A new flexible and accurate method of generating ultrasounds. Instead of using one single transducer and one single ultrasound beam, this method uses different crystals to generate multiple focused beams. The ultrasound beams emitted by phased array probes can be electronically oriented, focused and steered.

With this method the angle of the ultrasound beam can be selected to optimize the direction.

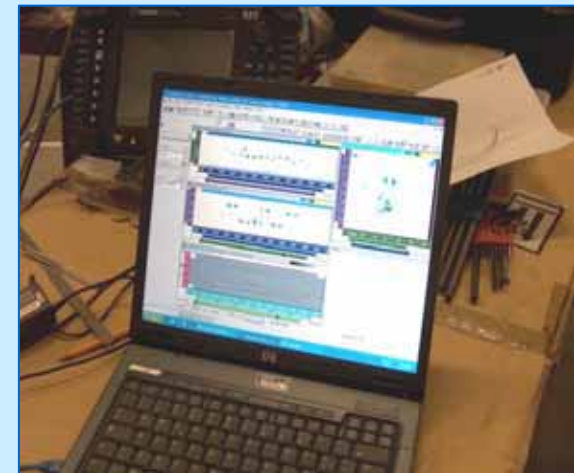



AUTOMATIC AND SEMI-AUTOMATIC ULTRASONIC PHASED ARRAY

The electronic recognition of the components provides a fast confirmation of their good working order and a wide range of solutions that a traditional ultrasonic method with one single transducer cannot offer. The variable angle beam (usually called sector or azimuth angle) can also be used to associate emission points to appropriate angles to optimize the probability of detecting defects.

The electronic focus optimizes the dimension and shape of the beam in relation to the position of the defect and increases the probability of detecting faults.





HOW PHASED ARRAY PROBES WORK

Phased array probes adopt a series of elements all individually connected with the same time delay frequency response. These elements are usually in groups from 4 to 16. The set up software usually calculates the time delay from the operator input or uses preset files.

The time delay values are calculated in advance using the time necessary from the focal position and the scanning is activated by each single “Focal law”.



HOW PHASED ARRAY PROBES WORK

The time delay of the circuits must be set at about 2 nanoseconds to provide the required accuracy.

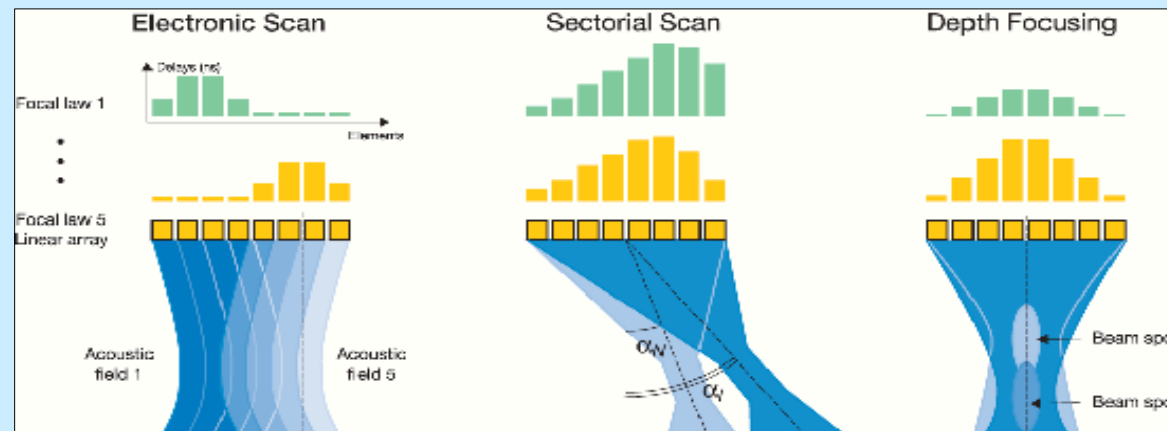

Set up information is electronically saved and only a few seconds are needed to retrieve it. Changes in calibration are fast compared to the physical adjustment of traditional transducers.



PHASED ARRAY SCANS

The use of electronic emission and reception offers a wide range of scans.

The main types of scans are:

1. electronic scan
2. sector scan
3. linear scan of components



PHASED ARRAY INSTRUMENTS

Phased array units with manual, semi-automatic and automatic functions can be used by one single operator to check any type of welding.





ADVANTAGES OF THE PHASED ARRAY METHOD

- Very fine beam grids: small matrices provide greater flexibility in the inspection of limited areas compared to traditional transducers.
- Absence of ionizing radiations.
- It can be carried out at the same time as other activities.
- Immediate results.
- Recording on file of scans carried out.



TOFD (TIME OF FLIGHT DIFFRACTION)

Tofd is a very powerful ultrasonic defect detection method. The tips of a reflector positioned inside the material to be checked are analyzed and, thus, the reflector's height, length and position in the thickness can be compared to defined criteria in order to assess their acceptability.

It can be carried out with the Phased Array method or with separate probes.

Combined with linear or sector Phased Array scanning the P.O.D (probability of detection) rises up to 95%.

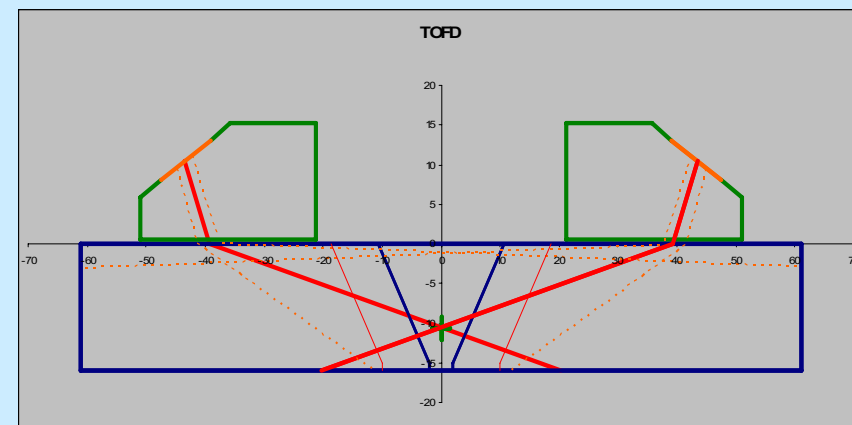
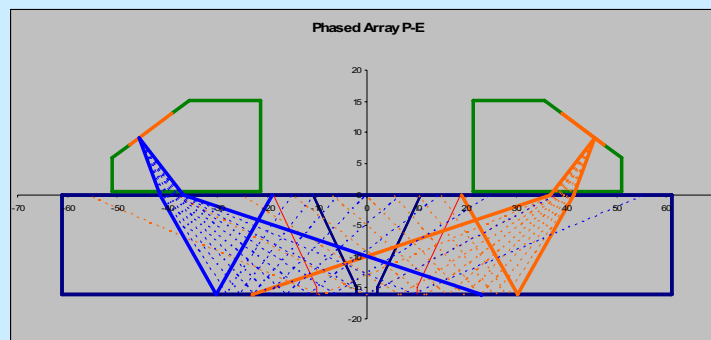



TYPICAL TOFD IMAGE

Lateral Wave

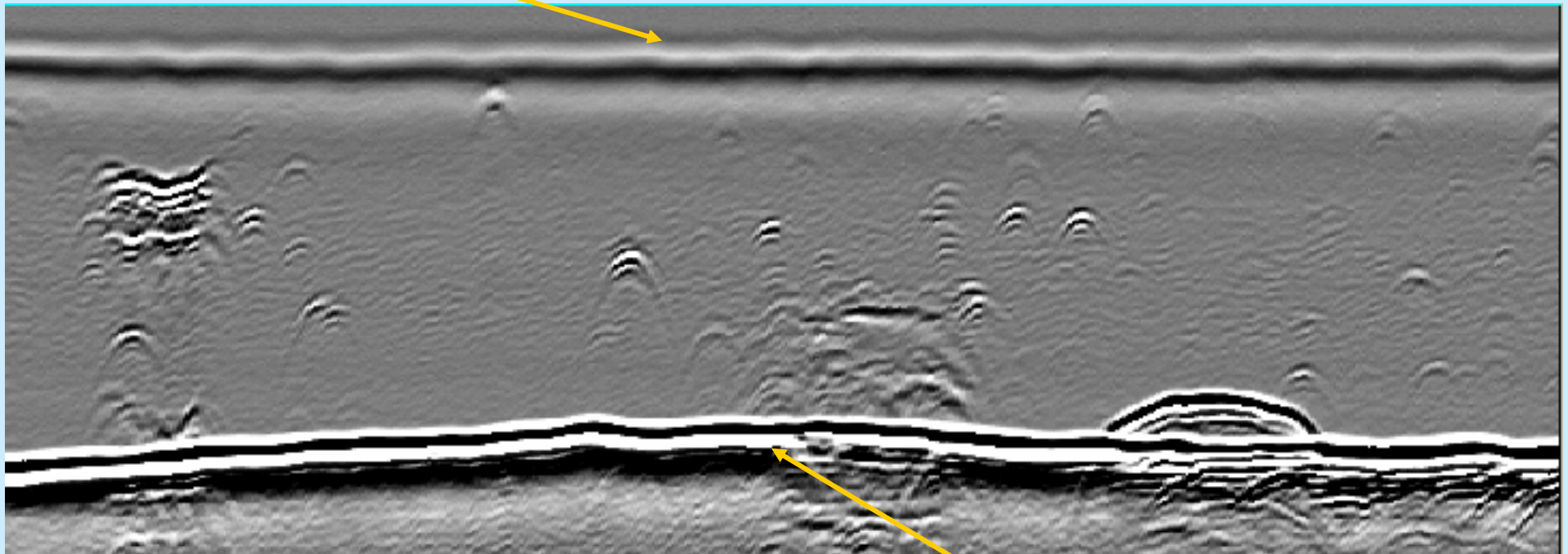

Back-wall Echo



EXAMPLE OF DETECTION OF SUPERFICIAL CRACK USING TOFD METHOD

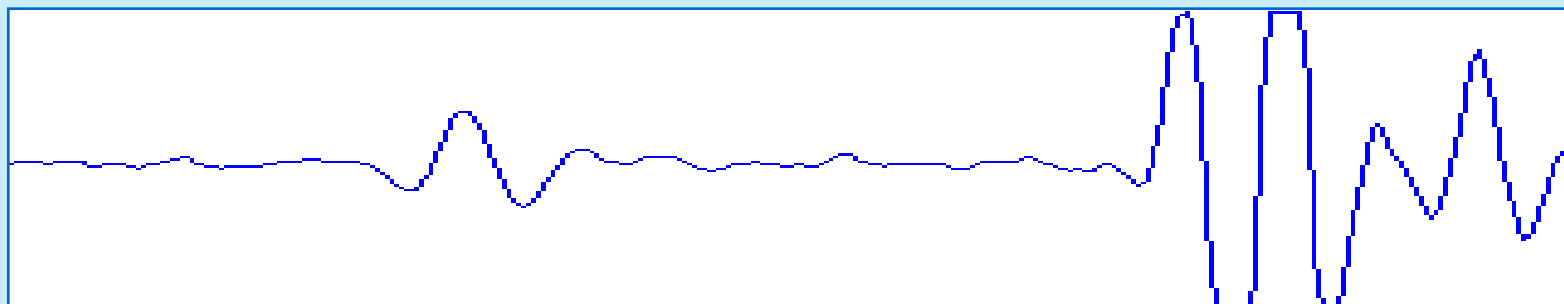
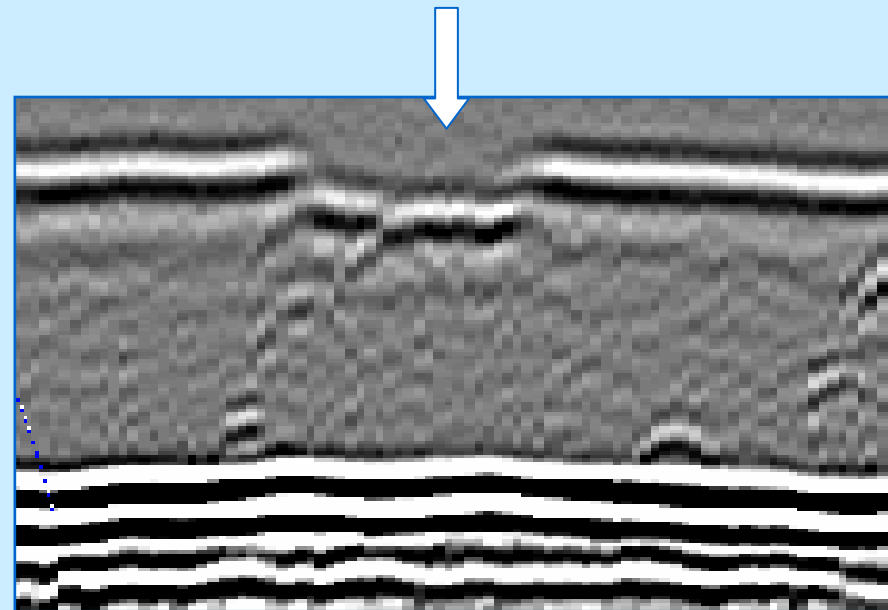
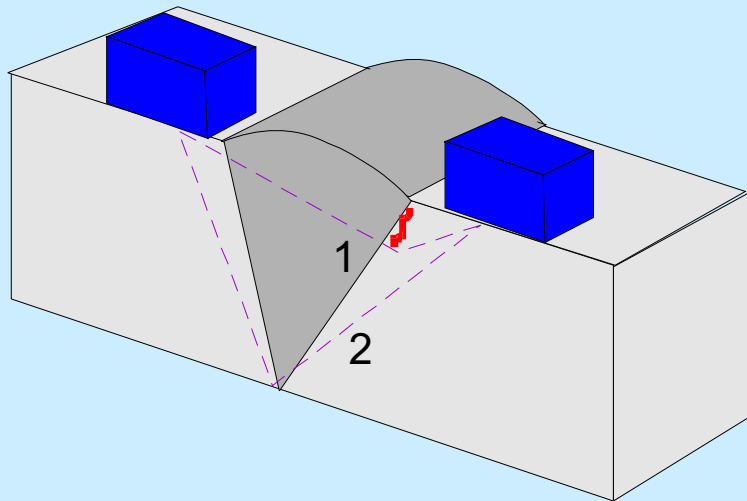



ACOUSTIC EMISSION



Acoustic emission is the only method that can provide in real time a result on the integrity of a structure during operation.

This method examines the dynamic reaction of the tested object to the load applied without any external intervention.

Acoustic emission is a non invasive testing method for structures.



ACOUSTIC EMISSION



The acoustic emission sensors “listen” to the structures at a frequency between 20-300 KHz and can detect micro-structural defects (cracks or detachment of material).

Using the difference in the time of arrival of the signal they detect the position of the source.

100% monitoring of a structure under pressure.

Allows to study in real time the movement of known or unknown defects in relation to a given load applied and to transmit data in remote.



DIGITAL RADIOGRAPHY

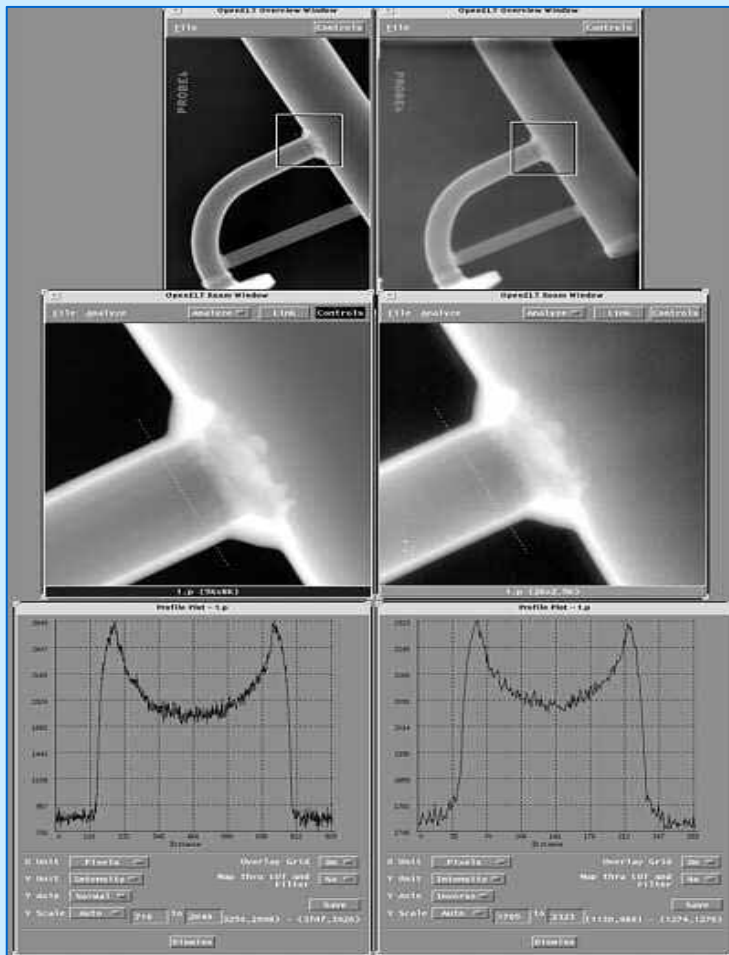

Digital Radiography offers an economic method to inspect insulated pipes. It:

- allows testing when pipe is working;
- offers continuous monitoring of process lines including drains, with the exact evaluation of residual thickness;
- offers the possibility to improve planning of when to stop the system;
- reduces costs for removal of insulation and reapplication of insulation;
- avoids conventional thickness testing;
- offers the possibility to check the presence of insulation and measure it.



WELDING CONSULTATION



- Development of welding specifications based on international standards (DNV/ BS/ API/ ASME etc.) and/or specific to the project;
- Development of welding procedures for projects (SMAW/GTAW/GMAW/SAW/FCAW etc.);
- Consultation for contractors, subcontractors and builders (for any type of welding problem);
- Assistance and final approval relative to welding procedure qualifications, including non-destructive testing, chemical analyses and mechanical tests (standard tests and corrosion tests);
- Assistance and final approval for welder qualifications (in accordance with any standards);
- Assistance and support through certified professionals; definition of programs for continuous improvement of welding processes;
- Consultation and study of particular applications (exotic materials such as: duplex, super duplex, clad and chrome steel etc.); weld engineering (from qualification of the procedure to completion of the project);
- Estimate of quantity and costs of welding consumables necessary for a project; estimate of daily production based on the different welding processes employed in the project;
- Study of the E.C.A (Engineering Critical Assessment) of pipeline welds.



MANUFACTURE OF CALIBRATION BLOCKS

Ecoglobal is specialized in the manufacture of calibration blocks for ultrasonic application (TOFD, Phased Array and Manual Ut), for any specific code request.

Using appropriate electro-discharge machines Ecoglobal can manufacture different configurations of artificial defects with a high level of precision, with tolerances in the range of 0.01 mm.

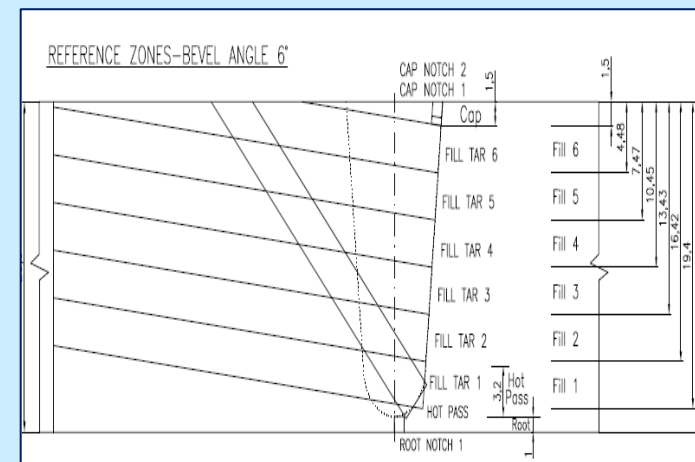
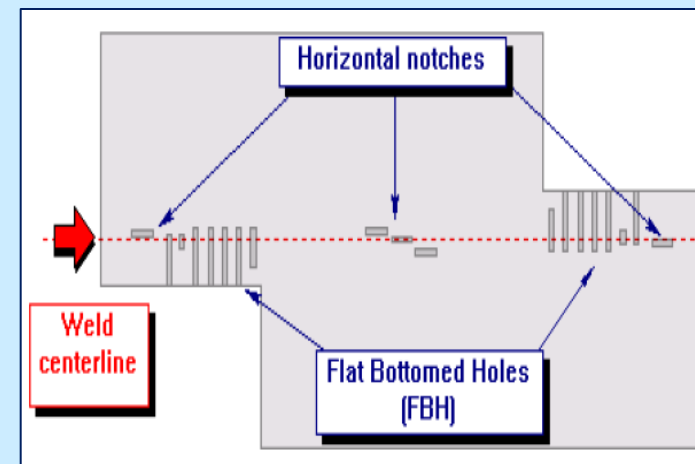



ELECTRO-DISCHARGE MACHINING SECTION

Electrical Discharge Machines and Spark machining is the most suitable method for making through holes, notches or other complex shapes, materials, such as aluminium, steel or even tungsten can be machined without difficulty. Ecoglobal is holding two EDM Machine and is specialized in the construction of calibration blocks”.





ECOGLOBAL MAJOR COSTUMERS

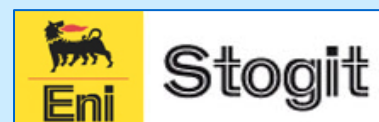

hydro drilling international S.p.A.





COMPLETED PROJECT AND IN PROGRESS 2011

- **ENI SERVIZI ITALY** (MAINTENANCE AND NDT LIFTING EQUIPMENTS) 2006 2011;
- **ENI CORPORATE UNIVERSITY** (TRAINING AND NDT COURSES);
- **WEI RUANDA** (MAINTENANCE LIFTING TOOLS);
- **T.R.S THANKS, CORTEMAGGIORE, CAORSO, OPERA, NOVA MILANESE** (MANUAL UT TESTING);
- **WEI, DRILLING TOOLS CORTEMAGGIORE** (MAGNETIC TESTING);
- **WEI TOWER DAMMAN ARABIA SAUDITA AND SHARJAH** (MAGNETIC AND ULTRASONIC TESTING);
- **WEI IRAN AND ALGERIA** (NDT ON DRILLING EQUIPMENT);
- **FF/SS TRENITALIA** (ULTRASONIC RAILWAIS TESTING), MILANO, PISA AND VICENZA TERMINAL FERROVIARI;
- **A.T.M. RAILWAYS MILANO** (PHASED ARRAY AXLE TESTING);
- **I. MESSINA COMPAGNIA DI NAVIGAZIONE GENOVA SHIP AND BARGE HULL** (ULTRASONIC INSPECTION);
- **I. MESSINA COMPAGNIA DI NAVIGAZIONE GENOVA** GUIDED WAVES TESTS OF TRACKS 2006 2011;
- **GAS PLANT MINERBIO STOGIT** (GUIDED WAVES AND PHASED ARRAY TESTING) ;
- **GAS PLANT SERGNANO STOGIT** (GUIDED WAVES AND PHASED ARRAY TESTING) ;



COMPLETED PROJECT AND IN PROGRESS 2011

- PIPELINE 24" **FIUMETRESTE-CENTRALE STOGIT** (GUIDED WAVES, PHASED ARRAY, CORROSION MAPPING);
- GAS PLANT **SERGNANO** THANKS **STOGIT** (ACUSTIC EMISSION);
- **SAIPEM SPA** FRAME AGREEMENT from 2003 (NDT TRAINING, TECHNICAL SUPPORT AND INSPECTION)
- RIVER CROSS ARDA PIPELINE **ACR REGGIANI** (GUIDED WAVES, CORROSION MAPPING);
- DRILLING YARD **PERAZZOLI** (DRILLING TOOLS MAGNETIC TESTING);
- DRILLING YARD **HYDRO DRILLING** (DRILLING TOOLS MAGNETIC TESTING);
- SAUDI ARABIA **AL ZAWIL/TECHNIP** INSPECTION THANKS (ULTRASONIC TESTING/CB SCAN);
- REACTOR PREFABBRICATION **ENI IN ROSSIGNANO** (PHASED ARRAY TESTING);
- REACTOR INSTALLATION **ENI IN SANNAZZARO DE BURGUNDI** (REFINERY (PHASED ARRAY TESTING);
- **SAIPEM** DRILLING **GALLIATE** (MAINTENANCE AND CERTIFICATION);
- **SAIPEM RAVENNA**, DRILLING TOOLS (MAINTENANCE AND CERTIFICATION);



COMPLETED PROJECT AND IN PROGRESS 2011

- GAS PLANT **SABBIONCELLO STOGIT** (GUIDED WAVES AND PHASED ARRAY TESTING) ;
- GAS PLANT **RIPALTA CREMASCA STOGIT** (GUIDED WAVES AND PHASED ARRAY TESTING) ;
- GAS PLANT **BRUGHERIO STOGIT** (GUIDED WAVES AND PHASED ARRAY TESTING) ;
- GAS PLANT **CORTEMAGGIORE STOGIT** (GUIDED WAVES,PHASED ARRAY AND MAGNETIC TESTING) ;
- GAS PLANT **SETTALA STOGIT** (GUIDED WAVES,PHASED ARRAY AND MAGNETIC TESTING) ;
- PIPELINE 16" **FIUME TRESTE ACR REGGIANI** (PHASED ARRAY TESTING) ;
- PIPELINE 8" **CHIETI SIMIND** (PHASED ARRAY TESTING) ;
- **SAIPEM** ENERGY SERVICES PIPELINE 3",4",6",8",16" CONNECTION GAS FIELD FIUME TRESTE (PHASED ARRAY TESTING) ;
- **CONSIAG** , LAMP POST TESTING (GUIDED WAVES TESTING);
- **DRILLMEC** , WELDING AND DRILLING TOOLS (PHASED ARRAY TESTING TESTING);
- CONSTRUCTION OF CALIBRATION BLOCKS FOR **ATM, STOGIT, SAIPEM, ACR REGGIANI, TOTAL, SIMIND, CMTI, ACCIAIERIA VALBRUNA**, SPECIALIZED IN NON DESTRUCTIVE TESTING



COMPLETED PROJECT AND IN PROGRESS 2011

- **ENI CORPORATE UNIVERSITY TRAINING AND NDT COURSES 2010**
- **SNAM RETE GAS PHASED ARRAY QUALIFICATION TRIALS 2010**
- **ERSAI KASHAGAN DEVELOPMENT EXPERIMENTAL PROGRAMME PROJECT 2010 2011**
- **MICOPERI SEALINE PHASED ARRAY AND TOFD GUENDALINA PROJECT 2011**
- **COSMI WELD INSPECTION PHASED ARRAY OIL CENTER VAL D'AGRI 2011**
- **MICOPERI SPOOL INSTALLATION PHASED ARRAY 2011**
- **CMTI PHASED ARRAY TESTING PIPELINE GAS PLANT FIUME TRESTE 2011**
- **MC PROJECT ULTRASONIC INSPECTION 2011**
- **PETROMAR PLNG PROJECT AT SOYO ANGOLA 2011**
- **DRILLMEC INSPECTION AND MAINTENANCE DRILLING TOOLS 2008 2011**
- **BESCO INSPECTION AND MAINTENANCE DRILLING TOOLS 2009 2011**
- **SAIPEM SCNL USAN DEEPWATER DEVELOPMENT PROJECT 2010 2011**
- **ESDRA COSTRUZIONI ULTRASONIC INSPECTION FPSO RISER UMBILICAL 2009 2011**



COMPLETED PROJECT AND IN PROGRESS 2011

- **CALIBRATION BLOCK** 2008 2011
- **STOGIT** GUIDED WAVES AND PHASED ARRAY TESTING **STOGIT GAS PLANT STORAGE** 2009 2011
- **SAIPEM** CONSULTANCY FOR AUTOMATIC ULTRASONIC INSPECTION **SHAH PROJECT - ABU DHABI** 2011